



**Scan to
Download**

NOTE: ALL WTS Instruction
Manuals are to be used only
by trained personnel.

OPERATOR'S GUIDE



TABLE OF CONTENTS

PAGE

OPTIMIZING PERFORMANCE of the EnviroSystem	2-3
PROCESS FLOW	4
SYSTEM MAINTENANCE	5
o Filter Press	5
> Opening & Closing the Filter Press	5
> Pre-Coating the Filter Press Cloths-Overflow	6-7
> Filter Press in Operation	8
> De-Watering the Filter Press	9
> Removing Solids from the Filter Press	10-11
> Cleaning the Filter Press Cloths and Plates	10
> Changing the Filter Cloths	12-13
o GrayTech	14-16
o AUTOMATION (where applicable)	17
> APCS BY WTS – DIGITAL SCREEN	17-18
TROUBLESHOOTING GUIDE	19
1. Control Panel	20
2. The Pit	20
3. Air Pump	21
4. Gray Water Pump	21
5. Filter Press	22
6. Cone Bottom Storage Tank (w/no pit or small pit)	23
7. Clear Water Storage Tank	23
8. Clear Water Pump	24
9. Ultraviolet Light	24
10. Bacteria Control	24
11. Automation – APCS	24
12. Over Temp	25
13. Variable Frequency Drives	26-27
DAILY OPERATION OVERVIEW	
ENVIROSYSTEM VALVING CHART	
GLOSSARY OF TERMS	

Copyright © 2025 Water Treatment Solutions. All rights reserved.
 No part of this manual may be copied or reproduced in any manner.

OPTIMIZING PERFORMANCE OF THE
ENVIROSYSTEM

Filter Press
CLEAR WATER

The balancing of water production by the EnviroSystem with the water demands in your shop is the most critical element to proper system operation and customer satisfaction. It is the basis of the sales contract with your company and the foundation of your system's design. The volume of water produced by the EnviroSystem is directly related to two key elements:

1. The filter press will yield higher volumes of water, also known as Filtrate, when freshly pre-coated; this volume will diminish with time as the press fills with solids.
2. The driving force behind water production is the air pump. The pump yield is related to three elements:
 - a) The volume of air being fed to the pump
 - b) The air pressure being fed to the pump
 - c) The amount of liquid pressure required to push the water through the filter press – Back Pressure (viewed at Back Pressure Gauge)

The volume of filtered water created by the EnviroSystem will, therefore, be related to where you are in the working cycle of the press (how full the press is with solids) and the working pressure and volume of the air being fed to the air pump.

Overall, the filter press will create substantially more water when freshly pre-coated. In general, you should adjust the air pressure at the air regulator to read _____ psi greater than the Back Pressure Gauge reading as measured by the psi gauge located between the air pump and the inlet to the press. This difference will be lower with smaller systems or those with lower clear water demands. (This is a starting point to be modified only by WTS).

The air pump delivers water based upon a performance curve. This curve is unique to your facility and will largely be dictated by the volume of solids you produce daily/weekly. The equipment you are running at any one point, and the volume and pressure of the compressed air available will determine the performance curve.

If you operate the EnviroSystem for maximum water production before required by your water demands, the storage tank will fill up and the system will turn off. When the air pump turns off the internal pressure in the press drops to zero and the pre-coat and solids may settle (by gravity) to the bottom of the void between the plates. The slumping of these solids will degrade the performance of the press and will lead to premature failure or fouling of the filter cloths. This is a common occurrence with new shops who have not yet reached a consistent level of production, or those who have chosen to substantially oversize their systems. Our install crew will teach you how to overcome this initial period of balancing frequent starts and stops. WTS will help you through this difficult time; **NEVER hesitate to call WTS.**

The objective of the EnviroSystem is to balance the clear water produced by the system with the clear water demand of your facility (ideal system performance), in accordance with your sales contract with WTS. The clear water storage tank is, therefore, your guide to this balance. By establishing an ideal water level and maintaining it consistently throughout the day, you prevent the frequent stopping and starting (explained above) that is detrimental to effective and efficient system performance.

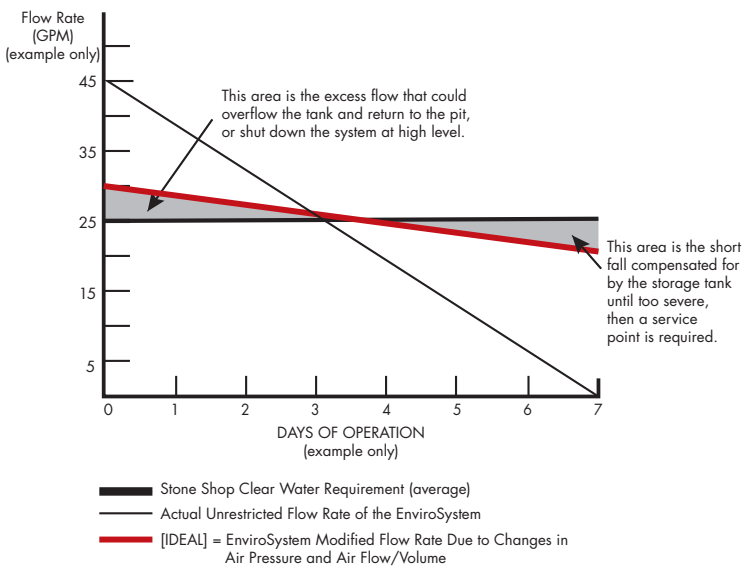

OPTIMIZING PERFORMANCE OF THE ENVIROSYSTEM (continued)

Consider the following, as the press fills with solids, the pressure required to push fluids through the press increases — not only does the water have to flow through the filter cloth, but also through the accumulated solids in the press. As the internal pressure in the press increases towards the same air pressure being fed to the pump (controlled by the air regulator), the volume of water produced by the press will diminish. At some point in time, if adjustments in the air volume and pressure are not made, the volume of water produced by the press will be less than the average water demand at your facility. The water level in the clear water tank will eventually drop to the point that the red light illuminates — if applicable.

To make adjustments in the volume of water produced by the EnviroSystem, increase the air pressure to the pump (by turning the knob on the pressure regulator) and/or increase the airflow volume to the pump (by turning the needle valve counterclockwise). **DO NOT** increase the air pressure or air volume dramatically! Small increases in the air volume and pressure may produce a significant increase in water volume. Use the psi differential discussed above as the guide. **DO NOT** exceed this differential without the authorization of WTS.

Again, ensure that the air-to-back pressure differential is maintained at _____ psi. This differential is calculated by the reading at the Back Pressure Gauge located in the plumbing line between the air pump and the inlet to the filter press and subtracting it from the reading at the pressure gauge of the air pump regulator. (This is a starting point for the differential. The differential is to be modified only by WTS either at training or thereafter by customer service personnel).

It is likely that this differential could be lower just after the press is cleaned, as the resulting clear water flow rate will be very high. Likewise, as the press nears a full state, you will not be able to maintain this differential even at air pressures of up to 100 psi. **NEVER EXCEED** 100 psi on the gauge at the press. Failure to heed this warning will void your air pump warranty.

Balance the EnviroSystem water production with water demands up to four times per day (by adjusting air pressure and air volume) to optimize the removal of solids from your process pit, to optimize the production of clear recycled water and to optimize the longevity of your filter cloths.

OPTIMIZING PERFORMANCE – (if applicable)

GrayTech GRAY/WHITE WATER

The objective of the GrayTech is to remove most of the larger micron solids from the gray water, providing more of a “white water” and filtering it to roughly 25-50 micron. As solids build up on the outer surface of the GrayTech filtration cartridge, the quality of the white water will improve, since the build-up of solids on the cartridge will help filter out finer particles.

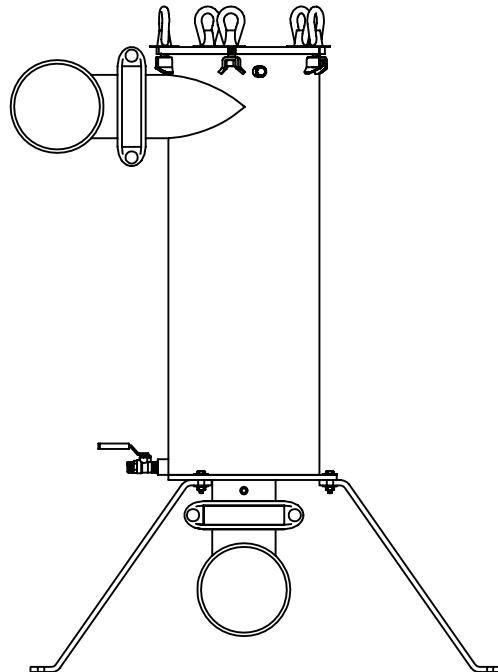

PROCESS FLOW

**Filter Press
CLEAR WATER**

The Filter Press functions as follows:

- The air pump draws water, contaminated with stone fines and/or glass swarf, from an in-ground pit or an above ground storage tank at your facility.
- The contaminated water is pumped by the air pump through the pre-coated filter press.
- The filter press removes sediment from the waste water to less than 2 microns nominal, producing crystal clear water.
- The crystal clear, filtered water is pumped into the clear water storage tank adjacent to the filter press.
- Crystal clear, filtered water is then pumped to critical polishing and cutting equipment, the spindle of your CNC equipment, the cooling of your water jet intensifier pump, certain edge polishers, hand routers and hand polishers, at the pressures and flow rates required, as specified in our sales contract. WTS systems remove suspended particulate to less than 2 microns, but they do not remove dissolved contaminants. Accordingly, the water jet intensifier pump manufacturer will likely specify additional "pre-treatment" of your city water for dissolved solids such as calcium, before it is fed to their pump ****do not allow softened water regenerate to be dumped into the trenches or the pit, please discharge to the sewer line as allowed by law.** In some cases it may be appropriate to feed a water softener and or reverse osmosis systems with "crystal clear" recycled water. This must be confirmed in advance with WTS engineers.**

PROCESS FLOW

**GrayTech
GRAY/WHITE WATER**

- If included in the design, a gray water system will draw water from the in-ground pit, or above ground storage tank, and pump the GrayTech filter water to your cutting, edging & polishing equipment and external cooling functions.
- Due to the cyclonic and crossflow design of the GrayTech, most solids are concentrated along the outer surface of the inner filter cartridge and continuously returned to the pit or above ground storage tank through the fast – flush **VALVE No. 14**, lower discharge port. Finer material is trapped by the inner screen/filtration cartridge.
- Pressure drop of $\leq 5-10$ psi across the GrayTech should be monitored. When the pressure drop reaches 10 psi, the filtration screen and cartridge should be removed and cleaned (see Maintenance).
- **VALVE No. 14** should be at least 1/2 way open when system is primed and running. This allows water to flow back to either a Pit or Cone Bottom Tank. Thus preventing plumbing to heat up and melt when equipment is not calling for water.

SYSTEM MAINTENANCE

FILTER PRESS

The filter press has four primary maintenance or service points: Pre-Coating, Operation, De-Watering, and Cleaning.

The filter plates are "coded" with either 1 or 3 dimples. This labeling indicates how internal channels within the polypropylene plates are structured. System failure will occur if this basic "coding" is ignored. It is therefore imperative to the proper working operation of the filter press that the plates are returned in the same order that they were removed. Each plate must be numbered in sequential order to ease re-assembly. This was organized at installation and training. As a fail safe, the order of plates according to the "code" is: 1,3,1,3,1,3, and so on (alternating dimples). With gaskets always facing front of the press.

Proper procedures are as follows:

OPENING/CLOSING THE FILTER PRESS (Manual Hand Hydraulic Pump)

To open the filter press to expose the dry cake, follow the steps outlined below. Use a dumpster or other "bin-type" storage device to remove/dispose of the filter cake.

FILTER PRESS - MANUAL

To open filter press:

1. After dewatering the filter press (see page 9), open pump valve slowly by turning the knob counterclockwise to release hydraulic pressure gradually.
2. Once the ram is retracted, carefully pivot the hydraulic ram upward and allow the ram to rest on the ram rest. Pull the follower plate back toward cylinder bracket. Some older style presses have rams that are connected to the follower plate and will automatically retract without manual involvement.

To close filter press:

1. Push the filter plates and follower plate forward.
2. Pivot the hydraulic ram downward into position
Note: See #2 in previous section to address alternate ram.
3. Turn the pump valve clockwise until hand tight.
4. Work the pump handle until pressure is 6000 psi.

Note: The hydraulic ram retraction process may take up to five minutes depending on temperature. If the handle or lever and needle valve (if any) is not switched fully to the open position, the hydraulic ram may not retract completely.

OPENING/CLOSING THE FILTER PRESS (Air Actuated, Semi Automatic Hydraulic Pump)

FILTER PRESS – SEMI AUTOMATIC

To open filter press:

1. Turn "selector" switch to "open."

To close filter press:

1. Turn "selector" switch to "close." The ram will slowly extend.

Note: The hydraulic pump is mounted on the end of the filter press that is opposite the manifold.

OPENING/CLOSING THE FILTER PRESS – "80" SERIES

- If the serial number on your filter press begins with "80" please follow the directions below to open or close your filter press.

To open filter press (Air Actuated Hydraulics):

1. Turn "hydraulic pump" switch to "off."
2. Turn "selector" switch to "open."

To close filter press (Air Actuated Hydraulics):

1. Turn "air supply" switch "on."
2. Turn "selector" switch to "close."
3. Once closed turn selector switch to pump.

TO OPEN FILTER PRESS (PEDAL HYDRAULICS)

1. If needle valve is present, open the valve
2. Ensure air relief is in up position
3. Push end of pedal labeled release
4. Once the ram is retracted, carefully pivot the hydraulic ram upward and allow the ram to rest. Pull the follower plate back toward cylinder bracket.
5. Some older style presses have rams that are connected to the follower plate and will automatically retract without manual involvement.

TO CLOSE FILTER PRESS (PEDAL HYDRAULICS):

1. Align filter plates in sequence towards the head plate.
2. Push the follower plate against the plate stack.
3. **Note:** See #2 in previous section to address alternate ram.
4. Pivot the hydraulic ram downward into position.
5. Push end of pedal labeled pump until gauge reads 6000psi.
6. If needle valve is present, close the valve.

SYSTEM MAINTENANCE (continued)

PRE-COATING THE FILTER PRESS CLOTHS

When the filter cloths have been cleaned and the filter press has been closed to the proper working pressure, the cloths must be pre-coated with WTS Pre-Coat.

Note:

- 1) WTS Pre-Coat must be purchased from WTS.**
- 2) Refer to the EnviroSystem manual for additional details on the filter press.**
- 3) Clear water pump switch must be on for the air pump to work, with the exception of a filter press with APCS.**
- 4) At the pre-coat stage Valve No. 10 requires _____ turns for your system.**

Failure to use Pre-Coat as specified by WTS will void WTS's warranty.

1. Close the solids process valve to the air pump VALVE No. 6.
2. Attach the pre-coat hoses to the two smaller ball valves (one discharging from the manifold at VALVE No. 8 and one on the feed side of the air pump at VALVE No. 9).
Note: VALVE No. 8 to top of tank. VALVE No. 9 to bottom of tank.
3. Fill the pre-coat container full with clear water (from city or the holding tank using the water re-circulation pump). Note: The air feed to the air pump must be off!
4. Open the small pre-coat ball valve on the feed side of the air pump VALVE No. 9.
5. Open the valve between the air pump and the center feed inlet of the filter press VALVE No. 5.
6. Open the valves at the top two corners of the manifold of the filter press VALVES No. 1 & 2.
7. Close the valves at the bottom two corners of the manifold of the filter press VALVES No. 3 & 4. These must remain closed until the filter press has completed its cycle and needs to be cleaned..
8. Close the valve that sends water from the manifold to the clear water holding tank VALVE No. 7.
9. Open the smaller pre-coat ball valve that is attached to the manifold VALVE No. 8. (discharging to the pre-coat tank).

10. Open Valve No. 12 and adjust the regulator pressure to _____. Turn the needle valve at the air pump, VALVE No. 10, _____ turns. This is customized for your system at training. Water should now circulate from the pre-coat container, through the air pump, into the filter press and exit through the two top corners of the filter press, traveling through the manifold and exiting the pre-coat hose through VALVE No. 8 back into the pre-coat container.
11. Let the water circulate for a few minutes to ensure the press is full of water. Add more water to the pre-coat tank as necessary to maintain its level, at least 1/2 full. Be sure to record pressure reading on back pressure gauge at this time. If pressure is 5 - 10 psi on clean water then additional pressure washing may be needed. Use De-Watering Steps then restart Pre-Coating Process. If pressure remains then cloths have been fouled and need to be replaced.
12. Adjust the needle VALVE No. 10 on the air pump to ensure that water returning to the pre-coat container is flowing at a rate of approximately 20 gpm. Measure the flow with the 5 gallon bucket. (15 seconds to fill the bucket = 20 gpm). Systems 4-8CF and below will have lower flow rates as set by WTS installers. (30 seconds = 10 gpm)
13. Place approximately 1.5 gallons of WTS Pre-Coat for every 1 cubic foot of filter press capacity in the pre-coat container while the water circulates – one gallon at a time, more or less. This process should take approximately 5 minutes, depending on the volume of the pre-coat added. Use the large spatula as a stir rod to mix the pre-coat media while it is being added. The larger the system, the slower the mixing process.
NEVER combine steps 12, 13 and 14! Circulate clear water first, then add perlite after all air has been eliminated.
14. Circulate the water through the filter press until the water in the pre-coat container is mostly free of grit and the majority of the solids have been removed. Approximately 10 minutes the pre-coat tank does not have to be clear – all that is required is most of the pre-coat to be processed. **Confirm that water returning from the press is always crystal clear. If not, call WTS immediately.**

Note: Do not disconnect the hose feeding the air pump from the water in the pre-coat container. Removing the hose can lead to improper pre-coat application.

SYSTEM MAINTENANCE (continued)

PRE-COATING THE FILTER PRESS CLOTHS

(continued)

15. The press is now pre-coated. Open the valve that leads from the manifold to the clear water holding tank VALVE No. 7. Close the pre-coat ball valve on the manifold VALVE No. 8. The water is now being pumped from the pre-coat container through the press and into the clear water holding tank.
16. When the pre-coat container is nearly empty (Do not allow pump to suck air into Press) close the ball valve that leads from the pre-coat tank to the air pump VALVE No. 9. Open the ball valve that leads from the process pit (or the Cone Bottom Tank) to the air pump VALVE No. 6. Pit or Cone Bottom Tank water will now be flowing from the pit, or cone bottom tank through the press and into the clear water storage tank. After each pre-coating process, the Filter Press must run for 6 to 8 hours without the air pump shutting off. To help facilitate this process, a by-pass line has been installed, open the clear water storage tank by-pass valve, VALVE No. 17, and allow it to remain open for approximately 6 to 8 hours after pre-coating to ensure that the system continues to operate without interruption. Installation personnel will instruct if this valve needs to be open longer than 6-8 hours.
17. Adjust the needle valve – Valve No. 10. Set the initial psi reading at the regulator to _____ psi, watch the water level in your tank. If the water level continues to rise in the tank when your equipment is running, reduce the needle valve until your water supply and demand are in balance. Reverse this process if you require greater clear water production. Be sure to adjust your pressure so as not to exceed a _____ psi differential (unless otherwise instructed by WTS). Review the "Optimizing Performance of the EnviroSystem" section of this guide.
18. After press has been running for several minutes, and to confirm that the press is creating clear water. Remove hose attached to Valve No. 8 and slightly open. Collect a sample from the stream with an empty water bottle. If the water is not crystal clear shut the press down and inspect your cloths for rips, holes, or bulging.
19. If necessary, disconnect the pre-coat hoses and properly store hoses and pre-coat container.

Note: After the cleaning cycle and the pre-coat process is complete the system must run uninterrupted for 6-8 hours with No. 17 at least ½ open. Failure to do so will void your warranty.

Note: In order to keep as much liquid in the press as possible, WTS recommends closing the press center feed valve (Valve No. 5) at the end of the day when the system is idle and in the "off" position. You must remember to re-open the valve when you return in the morning to start-up the system.

SYSTEM MAINTENANCE (continued)

FILTER PRESS IN OPERATION

1. If Cone Bottom Tank is present at the start of each day, utilize Blow Back Tee to free up any solids that may have settled over night. If not, proceed to step 2. This can be done by connecting air to Blow Back Tee, ensuring Valve No. 6 is closed and Valve No.19 is open. Once above Valves are in proper position and air is connected, open brass ball valve on Blow Back Tee for 30-60 seconds. Once complete proceed to step 2.
2. Valve No. 1, 2, 5, 6, & 7 should all be open. If a cone bottom tank is present, then Valve No. 19 should also be open.
3. Valve No. 3, 4, 8, & 9 should all be closed.
4. In general Valve No. 17 should be open ½ way at all times unless directed otherwise by WTS. The position of this valve is different for every customer and will be determined by the amount of solids collecting within the collection pit or cone bottom tank. By closing Valve No. 17, the filter press will shut off once the collection tank is full and by leaving it open it allows the filter press to always process solids. Please keep in mind that a baseline of 3 inches of solids is always needed in a pit/cone bottom tank to avoid cloth blinding from occurring.
5. Valve No. 10 should be open _____ turns for your application. If water needs to be generated faster, Valve No. 10 can be opened more for the time being, but should be reduced back down to normal position as notated above once the water level within the storage tank has filled and equalized with production demands.
6. Valve No. 12 should be open and the regulated air pressure adjusted to _____ higher than pressure reading on gauge after Valve No. 5. This comparison is known as the differential pressure. The gauge located after Valve No. 5 measures back pressure within the press.
7. The back pressure reading should be observed every _____ hours. Increase regulator pressure if differential pressure is less than notated in step #5. This will ensure the air pump continues to chug and does not stall. The air pump will no longer pump if back pressure and air pressure equalize.
8. Continue observing back pressure and increasing air pressure per step #5 until gauge after Valve No. 5 reads 70-80 PSI. At this pressure value you have reached the full point of the filter press.
9. Proceed to De-Watering section of the operators guide at this time.

**** Please keep in mind that these settings notated are our recommendation and some adjustments may be needed depending on current production volumes and operational equipment. Please call WTS to discuss if the system is not keeping up with demands.**

SYSTEM MAINTENANCE (continued)

DE-WATERING THE PRESS

The following procedures must be followed to properly remove water from the sediment that is trapped in the filter press. If you do not properly de-water the press prior to opening the press, the sediment will be the consistency of wet mud.

Note: The de-watering process will take roughly 10 minutes depending on the type of sludge and the amount of water that can be tolerated in the sludge by the customer. The times presented below are to be used as general guidelines.

1. Turn the air off to the air pump. This can be done by turning the needle valve clockwise until the valve is fully closed VALVE No. 10. If de-water regulator is present close Valve No. 12 instead.
2. Close the valve that is located between the air pump and the center feed inlet of the filter press VALVE No. 5.
3. Close the solids process valve to the air pump VALVE No. 6.
4. Close VALVE Nos. 1 and 2. Valve No. 3 remains closed. Open VALVE No. 4.
Note: Attach both pre-coat/de-watering hoses to the pre-coat tank before proceeding.
5. Open the smaller pre-coat valve on the manifold VALVE No. 8.
Note: VALVE No. 8 to top of tank.
 VALVE No. 9 to bottom of tank.
6. Close the ball valve that sends crystal clear water produced by the press to the storage tank VALVE No. 7.
7. Adjust the pressure on the regulator that feeds the air pump to 35 to 40 psi, for gasketed filter cloths and 40 to 60 psi for non-gasketed filter cloths. Please note that some systems have two sets of regulators, one for the air pump and one for the dewatering supply valve. Please adjust the correct regulator accordingly.
8. Put the hose attached to VALVE No. 8 in the pit, the pre-coat tank, or into the nearest trench to drain several gallons of water from the press. Slowly open VALVE No. 11 to send air into the press. Air will now flow into the upper left hand corner of the filter press. Water will be forced out of the sediment and out of the de-watering hose attached to the manifold VALVE No. 8.
9. **WAIT FOR 5-10 MINUTES** allowing water to be driven from the sediment. If it takes more than 20 minutes to dewater please call WTS.
10. Add time to your dewatering to harden mud. Dewater for a shorter time to keep more water in mud.
11. Slowly open VALVE No. 3. This will drain water accumulated in the bottom left portion of the filter press.
12. Close the valve when the flow of water subsides. VALVE No. 3.
13. Repeat steps 11 & 12 several times until water no longer flows freely from the press.
14. Close the air valve VALVE No. 11. Make certain all air pressure is removed from the press by leaving VALVE No. 8 open and observing the back pressure gauge reading.
15. Open all VALVES Nos. 1- 5 on the manifold before opening the filter press. Keep the storage tank feed valve, and the pit water suction valve to the air pump VALVE Nos. 7 & 6 respectively closed.
16. As the press is opened, if large quantities of water remain and filter cake formation is poor, call WTS immediately. Cycles longer than 10 minutes with excessive amounts of water in the press means poor cake formation and cloth blinding.

SYSTEM MAINTENANCE (continued)

REMOVING SOLIDS FROM THE FILTER PRESS – MANUAL DESIGN

As the follower or push plate retracts, the plates can be separated by hand and the filter cake will become exposed. Use the wide blade plastic scraper provided by WTS to remove the cakes. Periodically inspect plastic scraper for defect or sharp edges that could cut the cloth.

Carefully scrape any residual solids off the inside of the plates. Remove the plates from the press and pressure wash them according to the instructions in this guide. Some customers pressure wash the cloths while in the press.

As noted on page 9, #15 in the “De-Watering the Press” section, if when opening the press you observe large quantities of water draining from the press and what appears to be poor cake formation, call WTS immediately – you are experiencing cloth blinding and corrective measures must be taken.

CAUTION:

The filter cloths are constructed of a woven polypropylene fabric that may rip if sharp objects come in contact with them. DO NOT use a razor knife or other sharp object to remove the filter cakes.

Do not aggressively pry the cakes out of the press as the rubber gasket or filter cloths may become damaged. The cakes should be easily removed by design. Damage to cloths, plates or gaskets caused by careless handling will void the manufacturer's warranty.

CLEANING THE FILTER PRESS CLOTHS & PLATES

After the filter cakes have been removed from the press, and before the press is used again, the cloths and plates must be cleaned.

Clean the cloths and plates as follows:

1. Remove the tail and intermediate filter plates from the press. Use caution when removing the plates. Damage to plate handles or plate body may result if the plates are not properly handled. We recommend that two people remove the plates to prevent damage. Again, in some designs, the plates can remain in the press frame. **Note:** In most cases you will not be able to remove the head plate from the filter press. The head plate is secured directly to the manifold of the filter press. DO NOT remove the head plate without the authorization of WTS.

2. Place the plates over your pit or in an area that will allow draining during pressure washing.
3. Pressure wash the plates one at a time. The pressure washer must be rated for 2,600 psi. Failure to use the proper pressure will result in premature cloth failure. Wash all sediment from the filter cloths and the frame of the plate. When one side is clean turn the plate over and repeat the process. The tip of the pressure washer should never get closer than six inches to the filter plates or filter cloths; and the spray pattern should be “fan like”, 40° not a direct stream. The cloths are clean when they return to a mostly white color. This cleaning process must include the head plate as well.
4. Check the cloths to ensure that there are no rips, tears, pulls or general mis-alignment. Pay special attention to the cloth around the center feed of the head plate to ensure there is no fraying or damage that will allow solids to pass through and to accumulate in the clear water tank.
5. Run your finger over the edge where the filter cloth meets the filter plate. Make sure the cloth has not pulled away from the plate. If it has, loosen the cloth where it has separated from the plate by carefully using a screwdriver or another dull, flat bladed object to pry the cloth out of the recessed groove. Loosen the accumulated solids from behind the cloth. Wash off the area behind the cloth and re-seat the cloth in the groove using a hammer and polypropylene plastic cloth wedge; or a pneumatic tool which can be purchased from WTS. (Auto Air Hammer w/ special tip) See also the “Installing New Filter Cloths” section.
6. For all plates, run your finger over each gasket to ensure that it is not damaged and is free of any sediment. **Note** – some flattening of the gasket will occur over time.
7. Replace the plates in the same order as they were removed. Make sure that the pattern on the plates repeats, “one dimple, three dimples, one dimple” etc.
8. When the cloths and plates are clean and installed in the proper order, the filter press can be closed. Refer to “Opening/Closing the Filter Press” section.

SYSTEM MAINTENANCE (continued)

REMOVING SOLIDS FROM THE FILTER PRESS – SEMI AUTOMATIC DESIGN**PLATE SHIFTER – SEMI AUTO**

1. Open the press as instructed above.
2. Move the Plate Shifter so that the push paddles are between the first two plates at the opening of the press after the ram has been retracted.
3. Press and hold the rocker switch in the direction of the opening to start the shifting sequence. The push paddles raise, then extend to force the filter plate to the opposite side. Motion will stop if the rocker switch is released.
4. Once the filter plate is moved across the opening, release the rocker switch. The push paddles will lower.
5. Press and hold the rocker switch in the direction of the feed end of the press until the push paddles are fully retracted. (Motion will stop if the rocker switch is released).
6. Insure the filter cake has dropped. If necessary use the scraper to gently assist with dropping the cake.
7. Return to step 2 until the plate stack is completely shifted.
8. Once the push paddles are lifted between the filter plate handles, the push paddles should move the filter plate across the opening in two seconds in a smooth shifting motion.

Note: Visit our website to see a video on this subject watertreatmentonline.com/videos/

SYSTEM MAINTENANCE (continued)

CHANGING THE FILTER CLOTHS

The filter cloths will become damaged and/ or worn out over time. When this occurs, the water flowing out of the press looks cloudy. The worn cloths may also plug or foul as well. When this occurs, the volume of water delivered by the press decreases dramatically (fresh pre-coated or not). The back pressure on the gauge above the air pump will also rise in a very short period of time as a result. If the cloths are damaged, worn out or plugged they must be changed. As noted earlier, new shops that are building their capacity to normal levels may experience premature fouling. This is normal but does require cloth replacement.

CHANGE THE FILTER CLOTHS AS FOLLOWS:

Order a new set of filter cloths. Please call WTS to order your cloths. Cloths must be ordered through WTS in order for you to maintain your warranty and the production of crystal clear water.

First, de-water and clean the press as specified herein. Once the press has been cleaned, begin removing plates.

REMOVING THE FILTER CLOTHS – GASKETED DESIGN

Lay a plate on a flat surface. With a razor or knife, cut the cloth along two faces of the cloth (along edge numbers 1 & 2 shown in Figure 1) near where the cloth is secured to the plate. The two cuts must meet each other. Peel back the cut cloth exposing the "rope" that is fastened into the groove. Use a pair of Channel Locks,

Vice Grips or Robo Grips to grab the rope as close to the face of the plate as you can. Rock your hand into the center of the plate to "pry" the rope out of the groove. Once the rope has popped out of the groove, the entire cloth can be removed following the directions provided in Figure 1.

With a razor blade or knife, completely sever the "neck" (#3 in figure 1) of the filter cloth, allowing the remaining cloth to be pushed through to the other side. Repeat the removal process on side two. The head and tail plates are one sided. The head-plate must remain mounted to the press manifold at all times.

REMOVING THE FILTER CLOTHS – NON-GASKETED DESIGN

In this design cloths are secured to the filter with external velcro strips or with zip ties thru eyelits. Either separate the velcro sections or cut the zip ties. The cloths are then simply extracted thru the center feed by cutting the cloths as explained above. The head and tail cloths are usually secured to the plate with a series of screws that must be removed. Observe the placement of these cloths, as their replacement is in the same configuration. Insure that cloths are tightly placed on the plates with no folds or loose fabric in between the plates.

WASHING THE FILTER PLATES

Wash the plates with high-pressure water to remove any accumulated sediment. Focus on the groove in the plate. Use a screwdriver to remove any stubborn deposits of solids, being careful not to damage the soft polypropylene plate material.

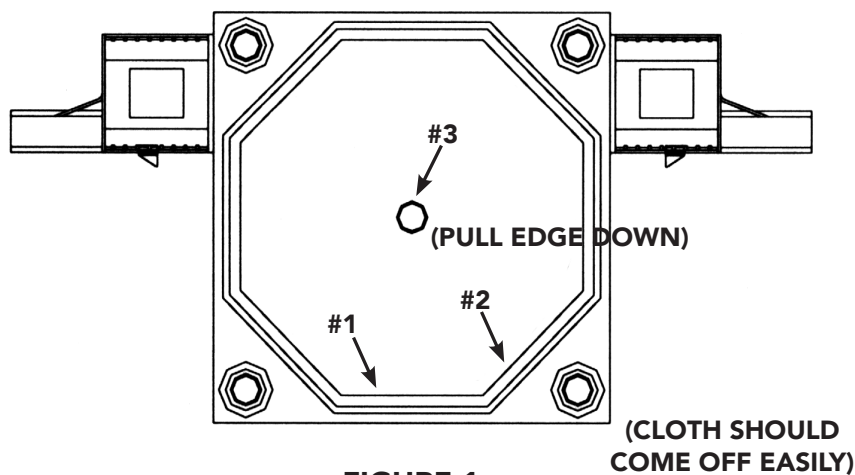
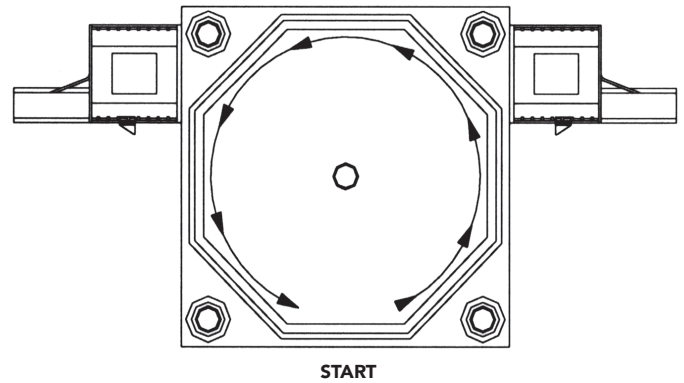

FIGURE 1

SYSTEM MAINTENANCE (continued)

INSTALLING NEW FILTER CLOTHS – GASKETED DESIGN

1. Feed one wing of new cloth through center feed hole.
2. Open the cloth and align the roped gasket edges of the cloth to the groove of the plate (noted with arrows on Figure 2).
3. Place roped gasket edge of cloth in the groove of the plate (Figure 3).
4. With the cloth seating wedge available from WTS, Pound the gasket into the groove using a 4lb. Hammer. You must buy a pneumatic tool from WTS to substantially speed up this process.
5. Seat one corner of the cloth into one of the corners of the plate.
6. Seat the cloth again in the next adjacent corner, along the same face, or edge of the plate.
7. Seat the roped gasket 1/2 way between the two corners.
8. Seat the remainder of the cloth along this edge before continuing to the next edge or section.
9. Work your way around the plate seating the gasket edge of the cloth as you go (Figure 2) repeating steps 6 through 9 (corner-to-corner).
10. Repeat this process on the other side of the plate.
11. The cloths for the head and tail plates have only one side. The head plate must remain mounted to the press frame at all times. You must install the cloth while the head plate is secured to the press. Please note that the head plate includes a locknut. Remove the locknut with a large pair of Channel Locks or Spanner wrench. If both the head and tail cloths provided by WTS are both solid cloth (no center hole cut in either), you must use a razor knife to carefully cut a new hole in what will become the new head cloth. Use the center feed as your guide, carefully mark the centerfeed hole with a sharpie. Lay the cloth on a clean, flat surface, cut an "X" in the center of the drawn circle, then cut out the pieces inside the circle, cutting the cloth just to the outside of the centerfeed hole, seal edges of this cut from fraying with the heat of a lighter or soldering iron.
12. If head cloth has a pre-cut center feed hole, place on plate for installation as noted in previous steps.
13. Seal with a bead of silicone sealant on back side of lock nut and tighten nut until snug.
14. Check out our video at: watertreatmentonline.com/training-videos/



START

FIGURE 2

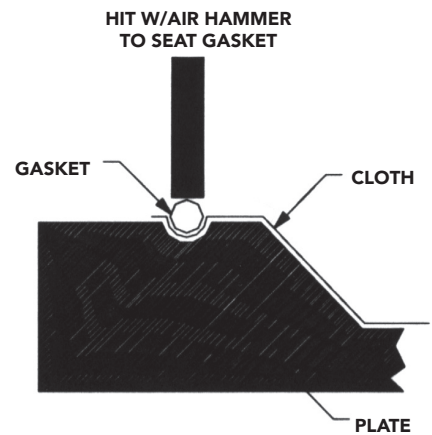

HIT W/AIR HAMMER TO SEAT GASKET

FIGURE 3

INSTALLING NEW FILTER CLOTHS – NON-GASKETED DESIGN

In short these are installed in the opposite manner compared to removal. Simply observe the placement of velcro sections or eyelits. They are designed with unique positions for plate handles and plate holes. Insure that cloths are tightly placed on the plates with no folds or loose fabric in between the plates.

Leaving loose fabric or folds will cause solids to pass which will become apparent during the pre-coat process or thereafter. Follow Step #11 for the head cloth cutout.

Secure Head and End cloths with screws.

GENERAL – GASKETED OR NON-GASKETED CLOTHS

Always confirm you are getting crystal clear water after cloth replacement – both during the pre-coat process and immediately after you begin processing waste water from the pit or cone bottom tank.

SYSTEM MAINTENANCE (continued)

GrayTech (GT)

SYSTEM OPERATION – PIT

(when suction line is pulling from a pit)

1. Priming the pump
 - a. Close the discharge ball valve located under the GT canister VALVE No. 13
 - b. Close the brass ball valve on the lower side of the GT canister VALVE No. 14
 - c. Open the brass ball valve on the upper side of the GT canister VALVE No. 28
 - d. Ensure the union on the suction (front side) of the pump is tight (use a small amount of liquid soap on the threads if needed to tighten correctly) and check the strainer lid to be sure it is sealed tight.
 - e. Remove GT lid and fill the canister with water; allow the water to flow into the pump and fill the plumbing to the foot valve. This may take a few minutes but should only need to be done if the pump needs to be re-primed. Loosening the plug on end of banjo strainer will allow for air to bleed out and prevent an air pocket. Retighten after.
 - f. Ensure the GT lid is on tight. A screwdriver works well for this. Do Not over tighten the lid as it will cause damage to the rubber gasket.
 - g. If your system has a foot valve, you must periodically clean the foot valve screen, some times daily. Failure to do so will reduce flow and pressure and may cause damage to the pump and motor.
 - h. Turn on the Gray Water Pump (GWP) switch on the control panel.
 - i. You should see the pressure slowly rise and water should be returning back to the pit from the hose attached to the ball valve on the upper side of the canister VALVE No. 28.
 - j. Allow pressure to build before opening VALVE No. 14 and closing VALVE No. 28. Verify the pressure is steady on the gauges at a minimum of 45 psi, if both gauges are showing the correct psi. Now you can slowly open the discharge to your equipment at the bottom of the canister VALVE No. 13.
2. Normal Operation
 - a. You will need to clean the filter cartridge inside the canister when the differential pressure, defined as the difference between the readings on the discharge gauge of the pump and gauge on your canister reaches 5-10 psi (see maintenance section below for cleaning instructions).
 - b. If your pressure differential is nearing the \leq 5-10 psi required to clean the GT filter cartridge and you do not have time to clean it immediately you can try "Fast Flushing" the GT canister to prolong the amount of time before cleaning is needed. "Fast Flushing" is a process in which you use your water flow in the GT canister to dislodge some sediment from the GT filter screen by adjusting the recirculation valve on the lower side of the canister VALVE No. 14. Alternate from opening VALVE No.14 wide open and shutting it down halfway quickly a few times. This will hopefully create a difference in the flow inside the canister and cause some sediment to leave the canister, prolonging your time until a full cleaning is needed. Be sure to return VALVE No. 14 to its halfway open position once finished. **NOTE:** If the gauges do not equalize you will need to clean the canister.
3. Quick Version Startup/Shutdown Procedures
 - a. To start the pump ensure that the discharge at the bottom of the GT VALVE No. 13 is closed, as well as the valve near the lower side of the canister VALVE No. 14 is closed. The ball valve near the upper side of the canister VALVE No. 28 needs to be open. Turn on the gray water switch on the control panel and allow pressure to build fully before opening VALVE No. 14 and close VALVE No. 28. Verify the pressure is steady on the gauges at a minimum of 45 psi, if both gauges are showing the correct psi now you can slowly open the discharge at the bottom of the canister VALVE No. 13. to send water to your shop and equipment.
 - b. To shut down the gray water pump begin by closing the discharge valve located at the bottom of the GT canister VALVE No. 13. Open the brass ball valve near the top of the canister VALVE No. 28. Close the brass ball valve near the bottom of the canister VALVE No. 14. Turn off the gray water switch at the control panel.
4. Failure to ensure proper pit water levels can cause the gray water pump liquid level float to interrupt its normal operation. This usually occurs at the 1/3 to 1/2 empty level of the pit. If the gray water pump shuts off, you will lose all gray water to your bridge saws and CNC cooling rings, etc., immediately, regardless of work in progress.

SYSTEM MAINTENANCE (continued)

GRAYTECH (continued)

SYSTEM OPERATION – PIT

- a. When a $\leq 5-10$ psi differential is achieved, it is time to clean the internal filter cartridge of the GT. Shut down the gray water pump (refer to section 3b above). Remove the lid from the canister, and then remove the filter cartridge inside. Use a garden hose to wash any sediment from the filter (recommended over the pit or trench). You may also need to spray the inside of the canister to ensure there is no sediment buildup on the bottom. Use a wet vac on the inside of the canister if needed. This is a vital step to ensure a build up of mud has not blocked VALVE No. 14 from the inside. Allowing Valve No. 14 to be blocked will cause premature seal failure and/or plumbing failure. Valve No. 14 acts as a cooling function for the pump when there is no facility draw and pump is running. Allowing build up will prevent a proper cartridge seal as well. Inspect the cartridge for damage, verify the U channel gaskets are in place, one on each end. Put the filter cartridge back in, screw the lid on, and start the pump as described above.
- b. The pump is protected from debris by a strainer on the suction front side of the pump. WTS recommends that you clean the strainer daily depending on the buildup of debris. Failure to do so can cause a loss of suction at the pump.
- c. You will also need to periodically change the seal in your pump. **You should check the pump daily for leaks; when a leak appears between the wet end of the pump and the motor, the seal needs to be replaced immediately.** If the leak is allowed to continue you run the risk of damaging your motor. Seals are not covered by any warranty, nor are motors and pumps damaged by failing to replace a seal. WTS recommends keeping seals on hand for quick replacement, and will provide detailed instructions on their installation when you purchase them.
- d. If your system has a foot valve, you must periodically clean the foot valve screen, some times daily. Failure to do so will reduce flow and pressure and damage the pump and motor.

SYSTEM OPERATION –

CONE BOTTOM TANK (CBT)

(When suction line is pulling from a CBT)

- 1. Priming the pump
 - a. Close the discharge ball valve located under the GT canister VALVE No. 13.
 - b. Close the ball or butterfly valve on the lower side of the GT canister Valve No. 14.
 - c. Ensure the union on the suction (front side) of the pump is tight (use a small amount of liquid soap on the threads if needed to tighten correctly) and check the strainer cap to be sure it is sealed tight.
 - d. Ensure the GT lid is on tight. A screwdriver works well for this. Do not over tighten the lid as it will cause damage to the rubber gasket.
 - e. Open brass ball valve on the upper side of the GT canister Valve No. 28.
 - f. Open the suction ball or butterfly valve between the CBT and the front of the pump Valve No. 20.
 - g. Hold a bucket under Valve No. 28 until all air has escaped the canister and a steady stream of water is visible. At this time close Valve No. 28.
 - h. Open ball or butterfly valve on the lower side of the GT canister Valve No. 14.
 - i. Ensure all brass valves located on the side walls of the CBT are open, Valve No. 25.
 - j. Turn on the Gray Water Pump (GWP) switch on the control panel.
 - k. You should see the pressure slowly rise and depending on the size of the motor will balance out between 60-80 PSI.
 - l. Once the pressure on the gauges builds fully, you can now slowly open the discharge to your equipment at the bottom of the canister Valve No. 13.
 - m. A placard has been installed on your Valve No. 14 handle notating how open it needs to be during normal operation. **If pressure drops below 45 PSI during normal operation please call WTS immediately.**

SYSTEM MAINTENANCE (continued)

GRAYTECH (continued)
SYSTEM OPERATION – CBT

2. Normal Operation

- a. You will need to clean the GT filter cartridge inside the canister when the differential pressure reaches $\leq 5-10$ psi. The differential pressure is defined as the difference between the readings on the discharge gauge of the pump and gauge on your canister (see maintenance section below for cleaning instructions).
- b. If your pressure differential is nearing the $\leq 5-10$ psi required to clean the GT filter cartridge and you do not have time to clean it immediately you can try "Fast Flushing" the GT canister to prolong the amount of time before cleaning is needed. "Fast Flushing" is a process in which you use your water flow in the GT canister to dislodge some sediment from the GT filter screen by adjusting the recirculation valve on the lower side of the canister Valve No. 14. Alternate from opening Valve No. 14 wide open and shutting it down halfway quickly a few times. This will hopefully create a difference in the flow inside the canister and cause the sediment to leave the canister, prolonging your time until a full cleaning is needed. Be sure to return Valve No. 14 to its hallway open position once finished. NOTE: If the gauges do not equalize you will need to clean the canister immediately.

3.1 Quick Version Startup

- a. To start the pump ensure that the discharge at the bottom of the GT Valve No. 13 is closed, as well as the valve near the lower side of the canister Valve No. 14 is closed.
- b. The ball valve near the upper side of the canister Valve No. 28 needs to be open.
- c. Open the suction valve between the CBT and the front of the pump Valve No. 20 and ensure there is a steady stream of water flowing out of Valve No. 28. Once confirmed close Valve No. 28.
- d. Open Valve No. 14 located on the lower side of the canister at least $\frac{1}{2}$ way, or to position instructed at training. Ensure all Valve No. 25 are open on the lower side wall of the cone bottom tank (only present if your system uses water mixing nozzles).
- e. Turn on the gray water switch on the control panel.
- f. Once the pressure on the gauges builds fully (must be at least a minimum of 45 psi) on both gauges, you can slowly open the discharge valve at the bottom of the canister Valve No. 13 to send water to your shop and equipment.

3.2 Quick Version Shutdown

- a. Close discharge valve located on the bottom of the canister Valve No. 13.
- b. Turn off gray water switch at control panel.
- c. Close valve on lower side of the GT canister Valve No. 14.
- d. Close suction valve between the CBT and the front of the pump Valve No. 20.
- e. Close mixing nozzles overnight. Do not forget to open prior to start up in the next cycle.

MAINTENANCE

Cleaning the GT Canister

- a. When a $\leq 5-10$ psi differential is achieved it is time to clean the internal filter cartridge of the GT. Shut down the gray water pump (refer to section 3.2 above). Remove the lid from the canister, and then remove the filter cartridge from inside. Use a garden hose to wash any sediment from the filter (recommend over the pit or trench). You may also need to spray the inside of the canister to ensure there is no sediment buildup on the bottom. Use a wet vac on the inside of the canister if needed. This is a vital step to ensure a build up of mud has not blocked Valve No. 14 from the inside. Allowing Valve No. 14 to be blocked will cause a premature seal and of plumbing failure. Valve No. 14 acts as a cooling function for the pump when there is no facility draw and pump is running. Inspect the cartridge for damage, verify the U channel gaskets are in place, one on each end. Put the filter cartridge back in, screw the lid on, and start the pump as described above.
- b. The pump is protected from debris by a strainer on the suction front side of the pump. WTS recommends that you clean the strainer **daily** depending on the buildup of debris. Failure to do so can cause a loss of suction at the pump.
- c. You will also need to periodically change the seal in your pump. **You should check the pump daily for leaks; when a leak appears between the wet end of the pump and the motor, the seal needs to be replaced immediately.** If the leak is allowed to continue you run the risk of damaging your motor. Seals are not covered by any warranty, nor are motors and pumps damaged by failing to replace a seal. WTS recommends keeping seals on hand for quick replacement, and will provide detailed instructions on their installation when you purchase them.

AUTOMATION – APCS BY WTS – DIGITAL SCREEN

THEORY OF OPERATION

The Automatic Pump Control System (APCS) is designed to enable the filter press to fill automatically and progressively in steps, without human intervention. It replaces the labor that would otherwise be required to adjust the air regulator and needle valve, described herein.

The APCS function is based on ladder logic with the use of a PLC. The following steps explain its operation.

1. Press Log In button on Log-In screen. For ease, the User and Password have been permanently saved.

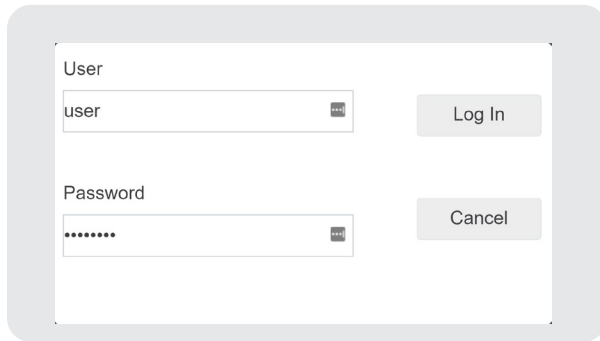

2. Once at main operating screen, press the On button on the lower right-hand corner. Box should go from a light gray in color to a teal. If hydraulic pressure is not within acceptable range the program will not begin. Valve No.17 must be open for the first 6-8 hours to prevent high level float in clear water tank from pausing the program and allowing perlite to "slump". A layer of mud must be able to form within the first 6-8 hours to hold perlite in place.
3. Settings will be preloaded at installation. If for any reason the system is not performing as trained, please call the office at 603.758.1900.

LOG-IN SCREEN

For ease of Customer, the User and Password have been permanently saved. Personnel will only need to press the Log In button to continue to the Main Screen.

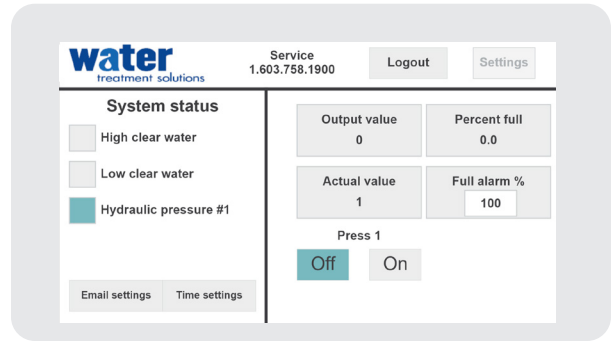

MAIN SCREEN

This screen allows the User to turn Automation on/off from the buttons located in the lower right-hand corner. A teal color indicates which button is currently active.

EMAIL SETTINGS TAB

Once inside the email settings tab, a Customer can input plant personnel information for whom they would like notified, regarding a low clear water level or when the filter press is full. There are six tabs along the bottom of the screen, where up to two individual's information can be inputted per tab. By pressing on the up arrow to the left of the 0, a box for Email 1 will appear. If the up arrow is pressed once more, another box will appear labeled Email 2. Only one email or phone number can be inputted in a single box. If you are attempting to input a cell phone number to receive a text, the instructions must be followed on the previous page. Each cell phone carrier has different text that must be entered after the number. For example, if the number you are attempting to input has ATT as a carrier, then the number should be shown as the following ... 5550004444@txt.att.net. There must be no spaces of any kind and the number must include area code. Once the proper email/phone number has been set, then each box must be checked for the corresponding day and time you would like alerts sent to the information notated in Email 1 & Email 2.

TIME SETTINGS TAB

Here personnel can check to see if the proper Date, Time, and Day are accurate.

Also, from the main screen, personnel can monitor the following information regarding their EnviroSystem...

- High Clear Water in storage tank
- Low Clear Water in storage tank
- Hydraulic Pressure of filter press
- Output and actual value of air being applied to air pump
- Percent full of the filter press

PRESS FULL ALARM

Along with the text/email notification of a press full situation, an audible and visual alarm will be triggered. This can be silenced by acknowledging the button on the touch panel of the automation box. At this point, the program has completed its cycle and the filter press will need to be cleaned before the cycle may begin again.

For any questions regarding the Automation please call our office at 603.758.1900.

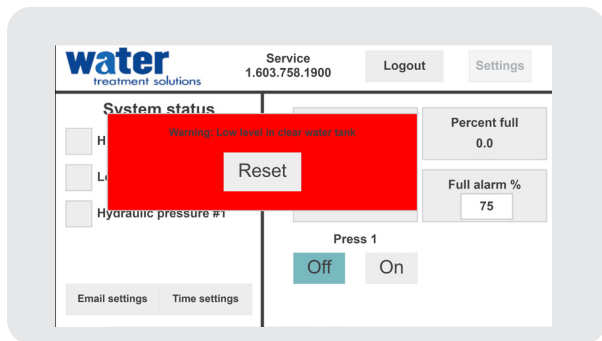

LOW CLEAR WATER ALARM

Along with the text/email notification of a low clear water situation, an audible and visual alarm will be triggered. This can be silenced by acknowledging the button on the touch panel of the automation box. Please check the percent full of the unit and call WTS at 603.758.1900, as there may be some modification that needs to be made to the settings if you are running out of water before the press becomes full.

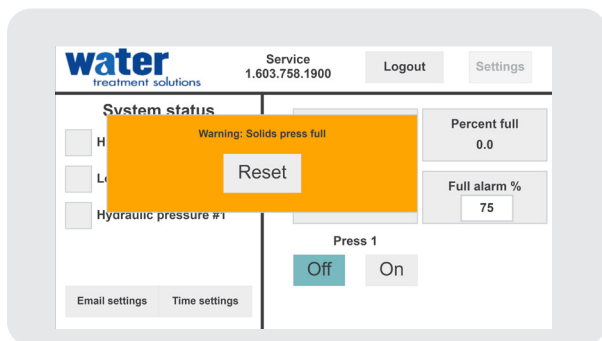

TROUBLESHOOTING GUIDE

The following guide identifies the more frequently encountered system problems and suggested customer-oriented solutions. If the problems encountered are not present in this guide or the suggested solutions do not solve the problem, please contact WTS. The service department will assist you to get your system operating quickly and efficiently.

Note: System Warranties and Liability are detailed in Appendix II in the EnviroSystem O&M manual.

This guide references other sections in this booklet. If another section describes the solution to a problem encountered, the reader will be referred to that section — it will not be restated here.

The clear water supply (by the EnviroSystem) and the demand (by your facility) or water balance, is one of the most critical aspects to proper system operation and overall performance. Be certain you are very familiar with the section entitled “Optimizing Performance of the EnviroSystem.” Again, for water balance problems, you will be directed to this section.

The following is a summary of system components reviewed herein:

1. Control Panel
2. Pit
3. Air Pump
4. Gray Water Pump
5. Filter Press
6. Cone Bottom Storage Tank
7. Clear Water Storage Tank
8. Clear Water Pump
9. Ultraviolet Light (optional)
10. Bacteria Control (call WTS)
11. Semi Auto Plate Shifter (call WTS)
12. APCS (call WTS)

1. Control Panel

The control panel is the brain of the system and it is U.L. listed. An electrical schematic is provided to both document WTS’s design and to allow or permit easier controls troubleshooting. Before engaging in any electrical work on any system component or within the control panel itself, YOU MUST ADHERE TO PROPER “LOCK OUT, TAG OUT” PROCEDURES. FAILURE TO DO SO MAY CAUSE SEVERE INJURY OR DEATH.

The door of the control panel includes a WTS label that describes the EnviroSystem, its voltage and amperage draw (older panels may include a main power switch) two (sometimes more) selector switches for the gray and clear water pumps, associated power ON lights and a red beacon or alarm light (optional). Be certain all switches are in the appropriate position when troubleshooting system components.

Inside the panel are the various components needed to control pumps, provide for control voltage and safety concerns. Both the gray water and clear water pumps are properly protected (with either fuses or circuit breakers), as is the control transformer (110 VAC, single phase systems do not have transformers). When troubleshooting the system, it will be necessary for the operator or maintenance person to be familiar with all electrical components, to have the proper tools and meters and have the ability to read and understand the electrical schematic.

In addition, the client was responsible for installing a fused disconnect switch on the wall within five feet of the EnviroSystem. Be certain this switch is in the proper position for operating the EnviroSystem – ON. Be certain it is in the OFF position when any work is being conducted in the control panel, and that proper “Lock Out, Tag Out” procedures are followed.

If the client does not possess the knowledge internally to troubleshoot electrical components, an outside electrician must be engaged to assist in this process. WTS is always available to answer questions at any time. Please call WTS. When calling WTS for assistance, the client must have the electrical schematic in hand, and must have all necessary electrical tools immediately available, including a meter capable of reading amps, volts and measuring continuity.

TROUBLESHOOTING GUIDE (continued)**2. Pit**

The only real problem that occurs in the pit is the gradual loss of water due to evaporation or water lost in the process. Periodically, twice a week or so, it will be necessary to add water to the pit. The water level should be a couple of inches below the level that the trenches enter the pit, allowing trench water and solids to cascade into the pit. Ideally, pit water level should not be allowed to back-up into the trenches.

Failure to ensure proper pit water levels can cause the gray water pump liquid level float to interrupt its normal operation. This usually occurs at the 1/3 to 1/2 empty level of the pit. If the gray water pump shuts off, you will lose all gray water to your bridge saws and CNC cooling rings, etc., immediately, regardless of work in progress.

The pit requires agitation to eliminate accumulation of solids in one area, for proper pit agitation follow this procedure:

- a) Check the depth of the solids in the pit with the air wand
- b) If solids are accumulating 6" or more in one location agitate the pit as follows:
 - i) Use provided air wand to move solids towards the Air Pipe Inlet. If an abundance of solids has built up this may need to be done over a course of a few days to avoid suction pipe from becoming clogged.

The pit floats will be addressed in the gray water and the air pump sections.

3. Air Pump

Simply stated, this pump is either ON or OFF, depending on the position of two system floats and the condition of the switches on the control panel. The lower float in the pit (if your systems has one) controls the low level operation (newer systems do not have this float). If the pit water level drops too low, the float will interrupt the operation of the pump by closing the solenoid which allows air to enter the pump. Alternatively, if the clear water storage tank reaches its highest level, a high level float will interrupt the operation of the pump. When the pump ceases to operate, no water enters the press and accordingly, no clear water is produced and none enters the clean water storage tank – preventing the tank from filling.

Problem: The air pump will not operate (the assumption is made that the press is not full).

Solutions:

1. Check to make certain the main electrical disconnect on the wall is in the ON position.
2. Check to see if the main power switch on the control panel is in the ON position.
3. Check to see that the clear water selector switch is in the ON position.
4. Adjust the pressure differential to the specified _____ psi (see optimization section). Make sure you adjust the correct regulator.
5. Ensure needle valve is in the OPEN position.
6. Ensure that the high level float in the clear water tank is in the DOWN position. Manually, move float, up and down to re-engage. (Listen for the solenoid to "click" open and close.)
7. Check the strainer to ensure it is free of any debris.
8. Check the inlet and discharge valves to confirm they are open.
9. If the previous steps have not solved the problem, break open the union located at the air inlet valve to ensure that air is freely moving to the air pump. Check the electrical connection to the solenoid.
10. Turn the system OFF and separate the union ends from the ball valve that is located between the air pump and the press. Remove the ball valve only if the pressure gauge reads 0. Turn the system ON. This will tell you if the water is freely moving.
11. Read the original equipment manufacturer's Operating Manual.

TROUBLESHOOTING GUIDE (continued)

3. Air Pump

Problem: Air pump makes loud noises.

Solutions:

1. Ball chatter can be a normal occurrence with air pumps, provided there is no loss of water flow or an interruption in water pressure (other than the normal surge caused by the design of an air pump as fluid cycles from side-to-side).
2. A rapid cycling of the pump, and loss of pressure and flow, usually means that the suction line has a blockage. Check the strainer to make sure it is clear, as well as the connected plumbing. This cycling, if accompanied by leakage from the pump, may mean a diaphragm is torn. Review pump manual for replacement procedure.
3. Check to ensure that the new version (Warren Rupp upgrade) of the air valve and muffler on the air pump were properly installed. This may require a call to WTS.
4. As the press fills with solids, as the pressures at the regulator and at the press increase accordingly, the sound of the normal cycling of the pump will become much louder and less frequent. This is normal.
5. Read the air pump Owner's Manual.

Problem: Leaks have developed on the air pump itself or in the associated plumbing.

Solution:

1. Tighten all bolts and fittings according to manufacturer's specifications.

4. Gray Water Pump

This pump delivers water to your equipment that does not require clear water. It is controlled by the mid level float in the pit and by the selector switch on the control panel. As long as there is sufficient water in the pit and the float is in the UP position, the pump will operate. Caution: As soon as the float travels to the DOWN position you will immediately lose all water flow to the associated equipment. Be sure to properly maintain your pit water level to ensure this problem does not occur.

Problem: The gray water pump does not produce water, adequate water flow or pressure.

Solutions:

1. Make certain the pit has sufficient water and that the pump is properly primed (as demonstrated at installation).

2. Check the pit float manually, moving it up and down to determine the pump is cycling.
3. Check all electrical ON/OFF positions, as explained above.
4. Check all ball valves to make sure they are open, including the valves at each piece of fabrication equipment.
5. Check to see that water is flowing through the bypass line flowing back to the pit. This valve must be 1/4 to 1/2 way opened. Do not close the valve at ANY time as permanent damage will be caused to the pump.
6. Check the strainer to ensure it is free from any blockage and debris.
7. Check the pressure gauge to see that at least 45 psi is being generated by the pump (after the first 10-15 seconds of startup).
8. If your system includes a GrayTech filter, clean the reusable cartridge with a hose if the differential between the inlet pressure and the outlet pressure is greater than 5 psi.
9. Confirm that water is flowing through the pump by separating the ball valve union at the discharge of the pump. (Only after turning the system ON and OFF accordingly.)
10. Check all suction side plumbing connections to ensure all fittings are tight and free of any leaks or fractures. This is the most common cause of gray water pumps losing their prime.
11. Consider opening the pump to check the impeller to ensure it is free of debris. Reprime the pump thereafter.
12. Always read the gray water pump's Owner's Manual before providing any pump service.
13. If GrayTech option is installed, remove cartridge and clean each morning to ensure proper operation

Problem: The pump leaks.

Solutions:

1. Tighten all fittings; retape with Teflon tape or other authorized sealant, if required.
2. If leaking occurs between the pump housing and the motor, a pump seal is most likely in need of replacement. Call WTS for assistance.

TROUBLESHOOTING GUIDE (continued)

5. Filter Press

The filter press, its plates, their cloths, the hydraulic ram and the manifold, form the heart of the EnviroSystem. The design and operation of these components, together with the pre-coat or filter aid, enable WTS to consistently deliver crystal clear water. When closed and in operation, there are virtually no moving parts.

The water which flows through the press begins in the pit or above ground cone bottom tank. After being strained of large particulate, the air pump provides the flow and pressure needed to allow the filter press to effect the separation of solids from the water. The single largest problem that is encountered with the press is the premature clogging or fouling of the cloths. This is caused primarily by the imbalance of water flows (explained in the "Optimizing Performance of the EnviroSystem" section) and low solids loading in newer shops where production levels are lower than normal. In addition, as time passes, these cloths are subject to normal wear and tear and require replacement semi-annually, on average.

Problem: No clear water is being produced.

Solutions:

1. Check to make sure the air pump is in good working order and that proper air and water pressures are being maintained. Follow the steps above to troubleshoot this component.
2. Check that the ball valve located on the manifold that sends clear water to the storage tank is open. Check the proper positioning of all manifold valves.
3. Determine if the clear water tank is full. If so, no water will flow as the air pump will have been disabled by the high level float in the tank.
4. Determine if the press is filled with solids and perform service as explained herein.

Problem: The water flowing from the press is no longer clear.

Solutions:

1. This usually indicates that a cloth is torn (or folded in the case of non gasketed cloths), or a section(s) is separated from the plates' groove, thereby allowing dirty water to mix with the clear water. Passage of solids can also occur around the center feed of the head plate. Inspect cloths after providing proper de-watering service and replace damaged cloth(s) as shown herein.
2. Replacement cloths must be purchased from WTS in order to maintain your system warranty and the production of crystal clear water.

Problem: The hydraulic ram does not apply the proper pressure.

Solutions:

1. Make certain the valve on the hydraulic pump is in the closed position. Try to pressurize the line again.
2. Check the hydraulic fluid level and add, as needed, the properly specified oil.
3. A seal within the hydraulic pump may need to be replaced.

Call WTS for assistance.

Problem: The ram/push plate does not fully retract.

Solutions:

1. Make certain the valve on the hydraulic pump is in the open position. Try to fully retract the plate again.
2. If the ram or the pump has been somehow damaged, you will need to manually force the push plate back. Call WTS for replacement parts.

Problem: During the de-watering process, no water exits the system through the pre-coat hose.

Solutions:

1. Check to see that ball valves throughout the manifold are in their proper position. Refer to the cleaning and pre-coat sections of this guide.
2. Make certain the air valve located on the manifold is open and that 35-40 psi of air is present at the regulator located on the wall. Check to see that the ball valve at the regulator is open and that you are using the correct regulator.

TROUBLESHOOTING GUIDE (continued)

Problem: After de-watering, the filter cake is very wet. Usually associated with a filter cake less than 50% capacity

Solutions:

1. Check to ensure you have performed all steps properly in the cleaning and de-watering sections of this guide.
2. If the plates are less than 50% filled with solids, you may have blinded off or clogged the cloths, possibly prematurely. Please read the "Optimizing Performance of the EnviroSystem" section of this guide thoroughly. Your water balancing procedures may have not yet been fine-tuned and your production levels may be less than normal during startup operations. WTS regularly recommends short term operating solutions to minimize this problem. Call WTS to advise.
3. It is possible that you are losing excessive amounts of water from the press when it is idled and shut down at night, resulting in a fouling of the upper portion of the cloths. WTS recommends closing the press center feed valve (Valve No. 5) at the end of the day once the system has been turned "off". You must remember to open it when you return in the morning.

6. Cone Bottom Storage Tank

(for clients with NO PIT or SMALL PIT)

This tank acts as the pit for any facility that has no pit. The floats in this tank, installed by WTS, operate exactly the same way as they do in a traditional below grade pit, with one exception. A high level float has been added in this tank to ensure that no transfer occurs if the tank is full.

7. Clear Water Storage Tank

This storage tank collects the crystal clear water that is produced by the filter press. The tank includes two or three liquid level floats. The low level float protects the clear water pump from running dry. That is, if this float drops to the DOWN position, this pump will stop.

The mid-level float operates a red beacon, an alarm light located on the top of the control panel (optional). If the water level in the tank reaches this level, and the float drops to the DOWN position, this indicates that the demand for water in the process exceeds the supply provided by the filter press. If this situation is not corrected, the water level will soon reach the low level and the flow of clean water to the process will be interrupted by the low level float.

The high level float is designed to prevent the tank from overflowing. Accordingly, if it reaches the UP position, the air pump will stop working and the filter press will no longer produce clear water.

Due to the nature of recycling systems, it is necessary to control the growth of bacteria in the system. At times it may be necessary to add chlorine to boost the disinfection capabilities of the system.

Again, the proper operation of the EnviroSystem involves proper water balance of supply and demand. Please review the "Optimizing Performance of the EnviroSystem" section very carefully where this balance is explained. Failure to maintain this balance is evident by the frequent starting and stopping of the air pump, associated with the constant refilling of the clear water tank to the high level float; and/or by the frequent enabling of the red beacon.

A by-pass line (**Valve No. 17**) has been installed on your clear water tank. WTS will properly instruct your personnel on its correct use in your production cycle. Failure to follow WTS's specific instructions with this by-pass valve will void your system warranty. Some older designs do not have a **Valve No. 17**. Call WTS to discuss alternative steps.

The primary purpose of the by-pass line is to ensure that a freshly pre-coated press receives the minimum 6 to 8 hours of operating time to properly coat the cloths with pre-coat and allow proper cake formation, thus protecting the system from premature failure. It is not to be more than 1/4 open, nor left open past the initial 6 to 8 hours after pre-coating, without authorization from WTS as noted above.

TROUBLESHOOTING GUIDE (continued)**8. Clear Water Pump**

This pump delivers clear water only to the pieces of equipment that require crystal clear water. The pump is controlled by the low level float in the clear water tank. This pump must never run dry and must always be in a "flooded suction" condition to operate. The pump is also controlled by the selector switch on the control panel marked accordingly. As long as there is sufficient water in the clear water tank allowing the low level float to be in the UP position, the pump will operate.

Caution: If the water level is allowed to drop in the clear water storage tank sufficient to drop the float to the DOWN position, the pump will stop immediately, all water to your equipment will be interrupted.

Problem: The clear water pump does not produce water, or sufficient water.

Solutions:

1. Make certain the clear water storage tank has more than 3 feet of water in it
2. Confirm that the Clear Water Switch is in the ON position.
3. Make certain that the low level float in the storage tank is in the up position
4. Check all ball valves to make sure they are open, including the valves at each piece of equipment.
5. Check to see that water is flowing through the U/V light (optional) or the re-circulation line and the bypass line into the clear water storage tank.
6. Check the discharge pressure gauge to see that at least 45 psi is being generated by the pump.
7. Consider opening the pump to check the impeller to ensure it is free of debris. Reprime the pump thereafter.

Problem: The pump leaks.

Solutions:

1. Tighten all fittings and flanges; retape with Teflon tape or other authorized sealant, if required.
2. Be sure not to over-tighten.
3. If the leak occurs between the pump housing and the motor, a pump seal is most likely in need of replacement. Call WTS for assistance. Always review the pump manual before providing any service.

9. Ultraviolet Light (Optional)

Located on the control stand, the Ultraviolet (U/V) light helps to ensure the control of bacteria growth in the water recirculating through the facility and the EnviroSystem itself. The U/V is comprised of three major service components: a quartz sleeve(s); an ultraviolet light bulb(s) and a ballast(s).

Problem: An odor has developed in the recycled water and the tank looks discolored.

Solutions:

1. At least annually, the quartz sleeve and U/V bulb must be replaced. Periodically, observe the light "site glass" on the stainless steel housing to see that a greenish or purplish light shows through the glass cover. Avoid prolonged staring at the light.
2. It may be necessary to assist the U/V light from time to time. WTS suggests adding a typical swimming pool chlorine tablet or "puck" or two to the tank and adding or replacing them as they dissolve. This will eventually add 2-3 ppm of chlorine to the water and will help kill any existing, excess growth. This level of chlorine will not harm your equipment or your stone and glass products.
3. Check pH level and if not at 7, call WTS. Proper pH level is critical to minimizing bacteria growth that will ruin cloths, impact water flow and cause odors.

Problem: The flow rate through the U/V light and into the clear water storage tank seems excessive.

Solution:

1. DO NOT CLOSE THE Ball valves that are located just before the inlet to the U/V light and just after the outlet, AS PERMANENT DAMAGE WILL BE CAUSED TO THE CLEAR WATER PUMP.

10. Bacteria Control

Call WTS for a specific set of instructions on how to control and eliminate the growth of bacteria in your system.

11. Automation – APCS

Call WTS for specific troubleshooting instructions.

TROUBLESHOOTING GUIDE (continued)

12. Over Temperature

CHANGING THE SETTING OF THE OVER TEMPERATURE RELAY CAN RESULT IN PIPE DE-RATING AND FAILING. PLEASE CONTACT WTS PRIOR TO MAKING CHANGES.

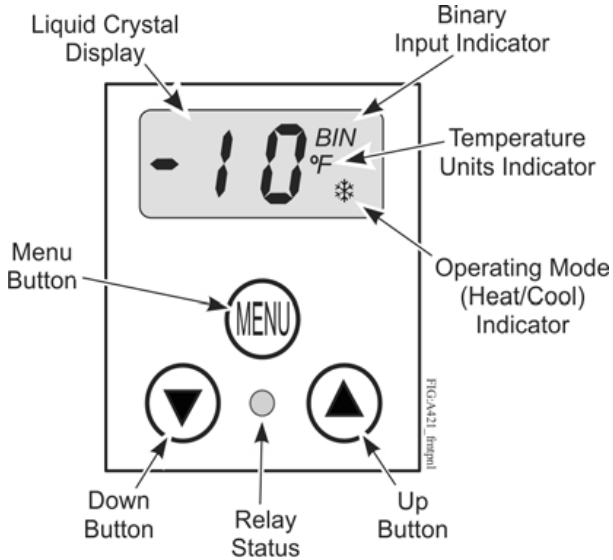

To change parameter settings the pump switch on the main control panel must be on. If it is not appropriate for the pump to be running, turn the

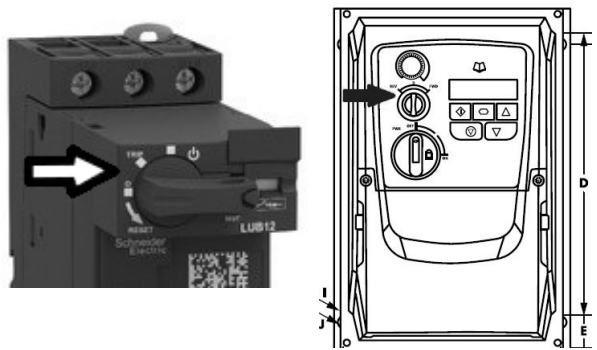

associated overload to reset or in the case of VFD turn the selector switch to stop mode.

The only two settings that should ever need to be changed are the on and off. On is the temperature that the alarm is triggered. Schedule 80 PVC under pressure will fail completely at 140 degrees F. It is recommended that the on setting be between 115 and 120 to allow time to stop it before it fails.

The off setting is the point the alarm is reset. It is recommended this be 5 degrees below the on point.

If the alarm buzzer is going off, open **Valve #14** all the way.

The handle should be in line with the hose. If the temperature does not start to come down, turn the pump off.

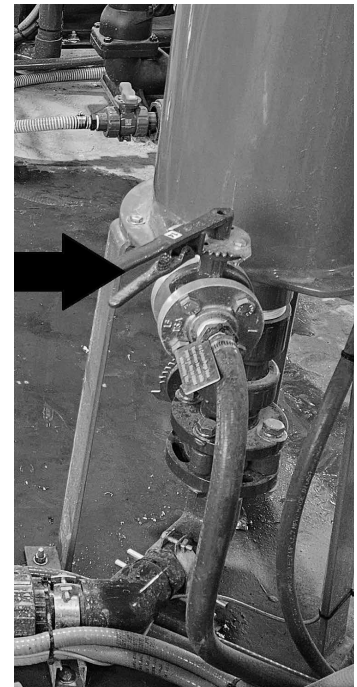

To silence the alarm, push the button under the buzzer, labeled alarm silence. The buzzer will rearm after the temperature drops below the set point.



TROUBLESHOOTING GUIDE (continued)

13. Variable Frequency Drives

AS NO TWO SYSTEMS ARE ALIKE, PLEASE REFERENCE YOUR O&M SUPPLIED WITH THE PROJECT FOR SPECIFIC PARAMETER INFORMATION.

CHANGING PARAMETERS

1. Start by making sure the Manual / stop / Auto switch is in stop mode. Straight up pointing to the 0.

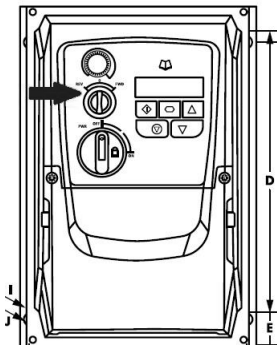

2. Next Press and hold the Navigation button for 2 seconds or until the display changes to P-xx.

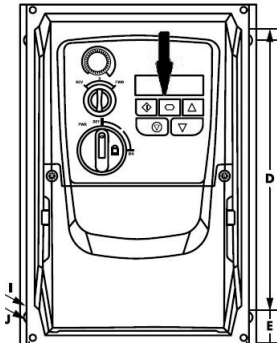

3. Use the up and down arrows to scroll to the parameter desired.

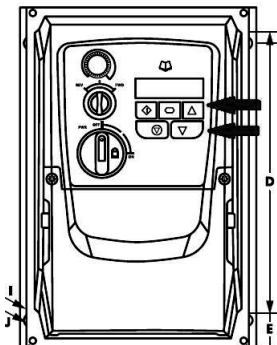

4. Push the navigation button once.

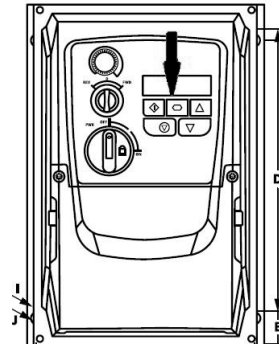

5. Use the up and down arrows to change the value.

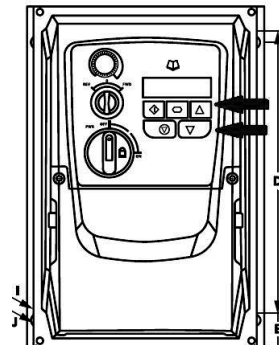

6. Push the navigation button once. The display should read P-xx

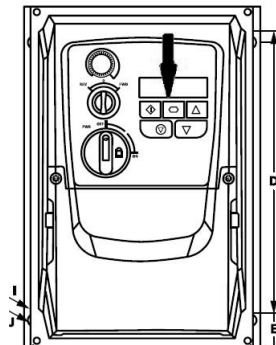

To Exit Programming

7. Press and hold the navigation button until the display reads STOP.

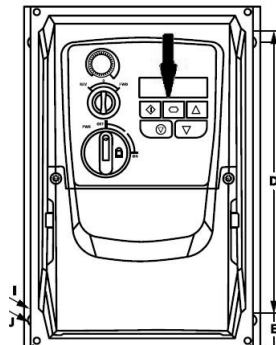

DAILY OPERATION OVERVIEW

START UP

Note: This is based on the pre-coat operation having been previously completed and the system has had an approximate 6 to 8 hours of running time. Thus Valve No. 17 is closed.

1. Inspect the system by walking around and checking for air, water or hydraulic oil leaks
2. Verify that the hydraulic ram is properly pressurized.
3. Clean out the strainers and their housing for the gray water pump and the air diaphragm pump. Be sure all O-rings are properly seated prior to closing.
4. If your system includes a GrayTech filter, thoroughly rinse off the reusable cartridge with clean water. **See manual for priming gray water pump under SYSTEM MAINTENANCE – GrayTech on page 14.**
5. Ensure power disconnect is ON and if your system has a main power switch located on the front panel it is also in the ON position.
6. Open clear water pump suction line Valve No. 18.
7. Ensure that clear water pump recirculation valve No. 16 is open.
8. Turn on clear water pump switch and inspect for leaks. If leaking is due to normal wear and tear on the seal, replace immediately. If leaking is due to an undetermined cause, call WTS immediately. Failure to do so will void any warranty.
9. Once pressure builds and equalizes (minimum of 45 psi), slowly open discharge valve to the shop Valve No. 15.
10. Open air pump suction Valve No. 6. If cone bottom tank is used also open Valve No.19 at the base of the tank.
11. Open air pump discharge valve No. 5.
12. Open air valve on manual regulator to feed air pressure to the pump Valve No. 12.
13. **See manual section filter press in operation on how to adjust air regulator on page 8.**
14. To start gray water pump **see manual section SYSTEM OPERATION – GrayTech – Section 3 Quick version start up on page 14. If you have a cone bottom tank see page 15.**
15. Follow Optimizing Performance of the EnviroSystem for maximum operation during the work day on page 2.

Valve No. 17 – Open _____ way for your system:

- YES
 NO

SHUT DOWN

1. Slowly close discharge of clear water pump to shop Valve No. 15.
2. Turn off clear water pump switch and inspect for leaks. If leaking due to normal wear and tear on the seal, replace immediately. If leaking due to an undetermined cause, call WTS immediately. Failure to do so will void any warranty.
3. Close clear water pump suction Valve No. 18.
4. Close air pump discharge Valve No. 5.
5. Close manual regulator Valve No. 12.
6. Close air pump suction Valve No. 6. If cone bottom tank is present also close Valve No. 19 located at the base of the tank.
7. To shut down gray water pump **see manual section SYSTEM OPERATION - GrayTech – Section 3 Quick Version Shut down on page 14. If you have a cone bottom tank see page 16.**
8. If system has main ON/OFF switch on front of the door, switch to OFF.
9. Agitate the pit with the air wand to push any collecting solids in the collection pit towards the air pump suction pipe. Be careful to not move so much to impact the pipe.



Process	Valve Number													33 APCS ONLY							
	1	2	3	4	5	6	7	8	9	10	11	12	13		14	15	16	17	18	20	28
De-Water Filter Press Close # 10 First	CLOSE	CLOSE	OPEN/ CLOSE	OPEN	CLOSE	CLOSE	CLOSE	OPEN	CLOSE	CLOSE	OPEN SLOW	OPEN					CLOSE				CLOSE
Open/Clean/Close Filter Press	OPEN	OPEN	OPEN	OPEN	OPEN	CLOSE	OPEN	OPEN	CLOSE	CLOSE	CLOSE	OPEN					CLOSE				CLOSE
Fill Filter Press with Water	OPEN	OPEN	CLOSE	CLOSE	OPEN	CLOSE	OPEN	OPEN	OPEN	CLOSE	CLOSE	OPEN					OPEN				CLOSE
Pre-Coat Filter Press	OPEN	OPEN	CLOSE	CLOSE	OPEN	CLOSE	OPEN	OPEN	OPEN	CLOSE	CLOSE	OPEN					OPEN				CLOSE
Empty Pre-Coat Tank	OPEN	OPEN	CLOSE	CLOSE	OPEN	CLOSE	OPEN	OPEN	OPEN	CLOSE	CLOSE	OPEN					OPEN				CLOSE
Water Production 0-8 Hours After Precoating	OPEN	OPEN	CLOSE	CLOSE	OPEN	OPEN	OPEN	OPEN	OPEN	CLOSE	CLOSE	OPEN					OPEN				CLOSE
Water Production After 8 Hours	OPEN	OPEN	CLOSE	CLOSE	OPEN	OPEN	OPEN	OPEN	OPEN	CLOSE	CLOSE	OPEN					OPEN				OPEN
APCS Air feed ball valve at air inlet (After Manual Precoat Completed)	OPEN	OPEN	CLOSE	CLOSE	OPEN	OPEN	OPEN	OPEN	OPEN	CLOSE	CLOSE	OPEN					SEE NOTE BELOW				OPEN
Clear Water Supply																		OPEN			OPEN
Gray Water Supply #20 Cone Bottom Tank Only																		OPEN			CLOSE
Gray Water Pump w GrayTech Canister Priming / Startup Only																					OPEN

Air Regulator Setting (by Valve # 12): _____ PSI higher than the centerfeed gauge back pressure.

Filter Press Hydraulic Ram Pressure: _____ PSI

Amount of Pre-coat Material per Cleaning: _____ Gallons





Needle Valve # 10 Setting for Pre-Coating : _____ Turns



GLOSSARY OF TERMS

English	Español	Reference Picture
Filter Press	Filtro Prensa	
Filter Cloth	Tela de Filtro	
Filter Plate	Placa de Filtro	
Filter Cake	Torta del Filtro	
Air Pump	Bomba de Aire	

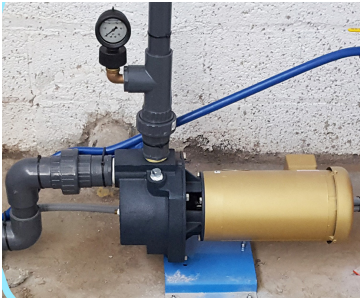
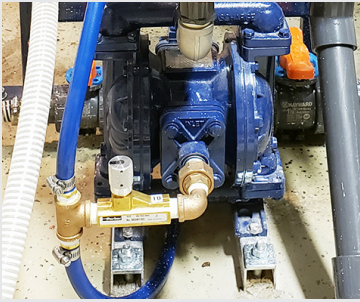
GLOSSARY OF TERMS

English	Español	Reference Picture
Filter Press Manifold	Colector de Tuberías del Filtro Prensa	
Clear Water Pump	Bomba de Agua Clara	
Gray Water Pump	Bomba de Agua Gris	
#10 Needle Valve	#10 Valvula de Aguja	
APCS Control Panel	Panel de Control (APCS)	

GLOSSARY OF TERMS

English

Español

Reference Picture

Clear Water Pump
Gauge

Indicador de la Bomba
de Agua Clara



Gray Water Pump
Gauge

Indicador de la Bomba
de Agua Gris



#12 Regulator
with Solenoid

#12 Regulador
con Solenoid



GrayTech Gauge

Indicador de GrayTech



GrayTech Cannister,
Cartridges, U-Channels
& Mesh Sock

Recipiente GrayTech,
Cartuchos Canales-U y
Media o Calcetín de malla



Aeration Wand

Vara de Aireación



OPERATOR'S GUIDE



6 Merrill Industrial Drive Hampton, NH 03842

watertreatmentonline.com

603.758.1900

